

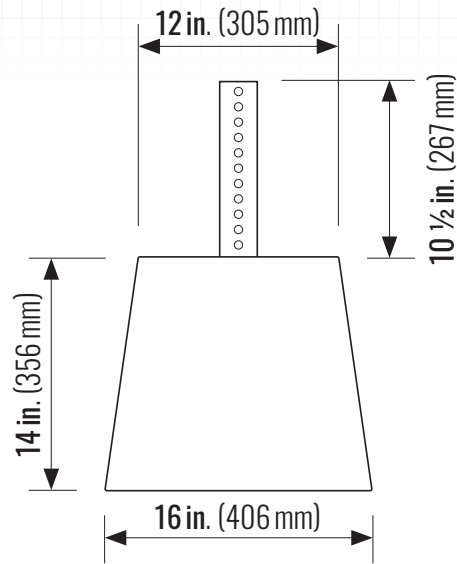

SIGN BASE, SQUARE AND ROUND

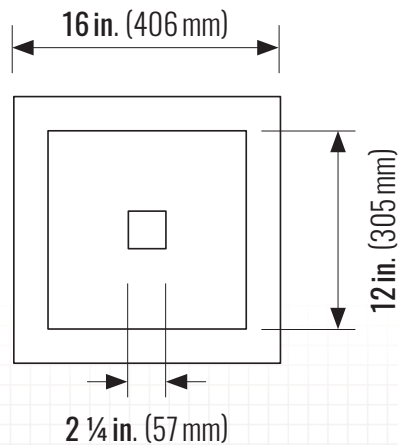

SIDE VIEW



TOP VIEW

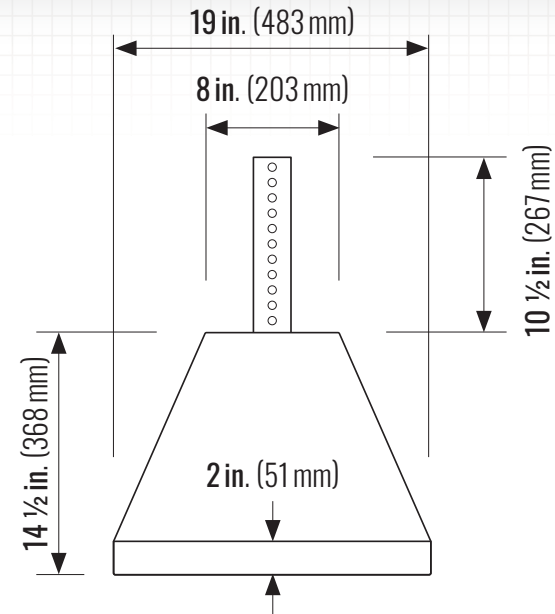

SIDE VIEW

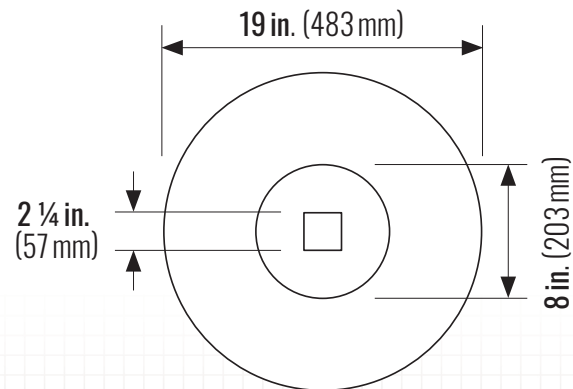

TOP VIEW



SQUARE:

Weight: 99.8 kg (220 lbs)
Volume: 0.042 m³

ROUND:

Weight: 93.0 kg (205 lbs)
Volume: 0.04 m³

PHYSICAL PROPERTIES:

Meets the requirements of CSA A23.1 and A23.4
Compressive Strength: Min. 35 MPa @ 28 Days
Concrete Contains: 5.0 – 8.0% Entrained Air