

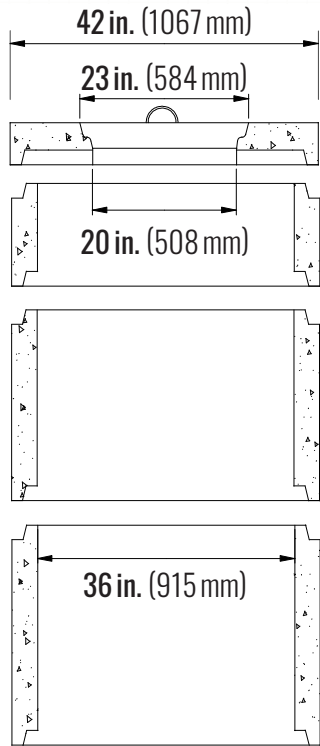

PRECAST PIPE - 915 & 1219 mm (36 & 48 in.) DIAMETER

36 in. (915 mm) COVERS



5 3/4 in. (146 mm)

12 in. (305 mm)

24 in. (610 mm)

30 in. (760 mm)

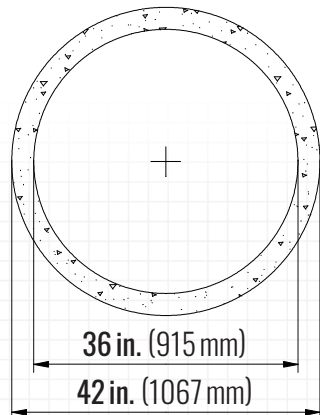

48 in. (1219 mm) COVERS

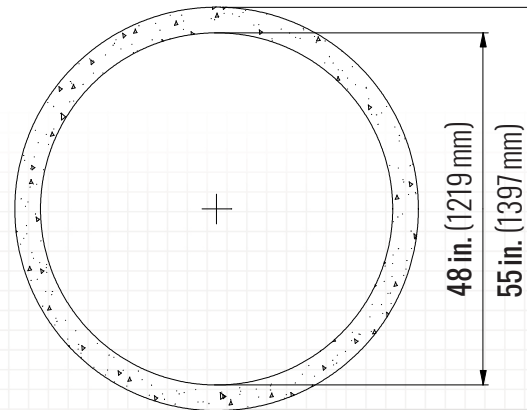
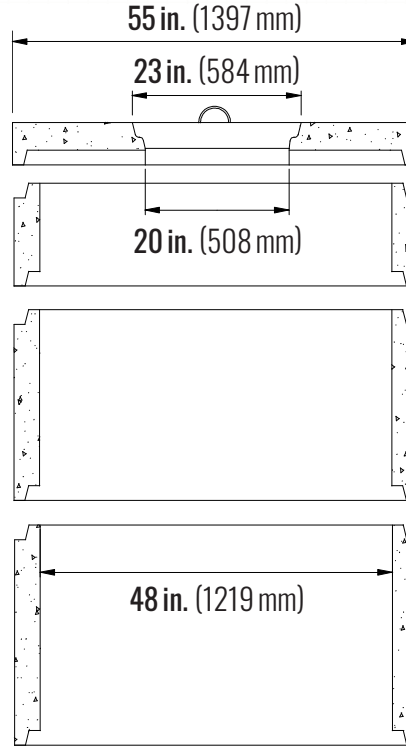

36 in. (915 mm) COVERS

COVERS:

508 mm = 45.4 kg
20 in. = 100 lbs

915 mm = 217.7 kg
36 in. = 480 lbs

PIPES:

915 x 305 mm = 181.4 kg
36 x 12 in. = 400 lbs

915 x 610 mm = 362.9 kg
36 x 24 in. = 800 lbs

915 x 760 mm = 453.6 kg
36 x 30 in. = 1000 lbs

PHYSICAL PROPERTIES:

Meets the requirements of CSA A23.1 and A23.4
Compressive Strength: Min. 35 MPa @ 28 Days
Concrete Contains: 5.0 - 8.0 % Entrained Air

48 in. (1219 mm) COVERS

COVERS:

508 mm = 45.4 kg
20 in. = 100 lbs

1219 mm = 362.9 kg
48 in. = 800 lbs

PIPES:

1219 x 305 mm = 254.0 kg
48 x 12 in. = 560 lbs

1219 x 610 mm = 508.0 kg
48 x 24 in. = 1120 lbs

1219 x 760 mm = 635.0 kg
48 x 30 in. = 1400 lbs

