

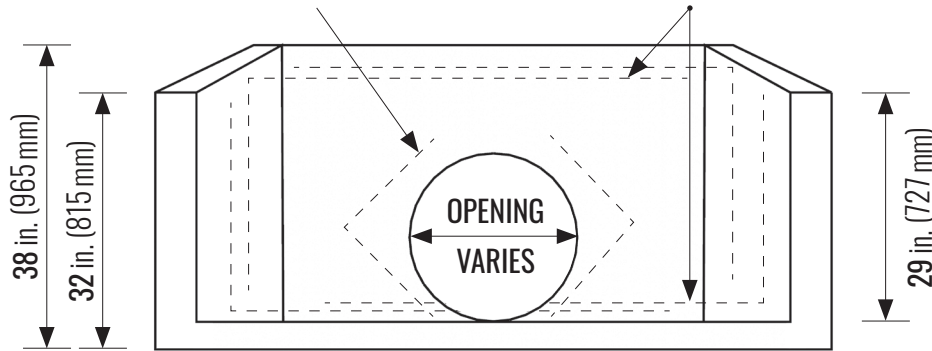

80 in. LENGTH OF 10 m REBAR BENT EITHER SIDE OF OPENING

TWO PIECES OF 10 m REBAR REBAR 80 in. LONG TOP AND BOTTOM



FRONT X-SECTION

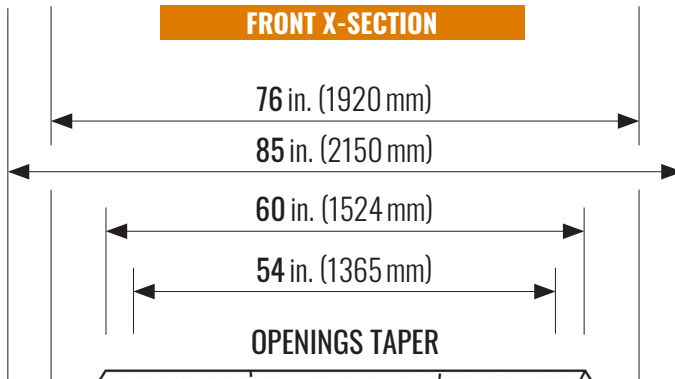

OPENINGS TAPER

VARIES

15 in. (381 mm), 21 in. (533 mm), 28 in. (711 mm)

TOP VIEW

6 in. (155 mm)

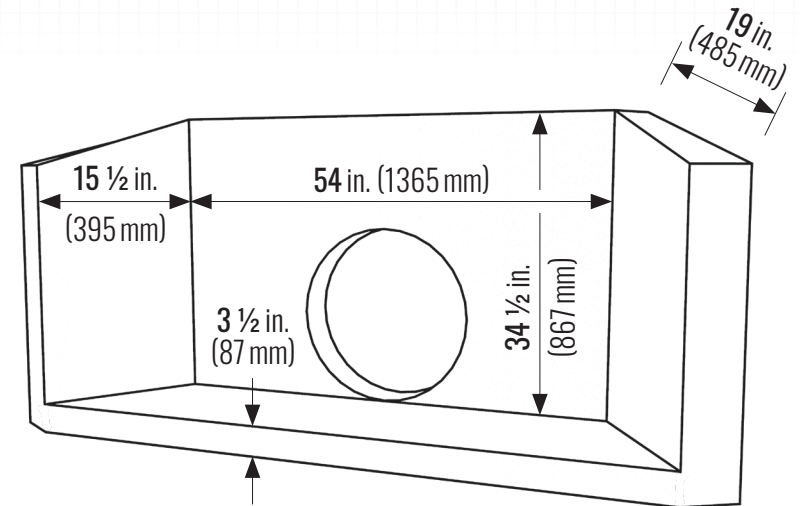

PERSPECTIVE

6 in. (155 mm)

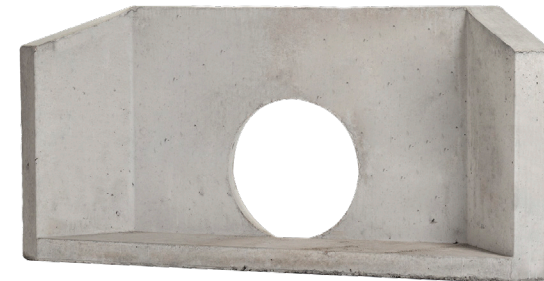

THERE ARE 3 OPENING SIZES AVAILABLE

- 17 in. (432 mm) tapers to 15 in. (381 mm) – [12 in. pipe]
- 23 1/2 in. (597 mm) tapers to 21 in. (533 mm) – [18 in. pipe]
- 32 in. (813 mm) tapers to 28 in. (711 mm) – [24 in. pipe]

PACKAGING:

Pc. Per Pallet:	2
12" Pipe:	916 kg (2020 lbs) +/-
18" Pipe:	901 kg (1986 lbs) +/-
24" Pipe:	885 kg (1950 lbs) +/-

PHYSICAL PROPERTIES:

Meets the requirements of CSA A23.1 and A23.4
 Compressive Strength: Min. 35 MPa @ 28 Days
 Concrete Contains: 5.0 – 8.0 % Entrained Air

PLEASE NOTE:

Products are made from natural material sources and therefore colour variations are common. Efflorescence is also a common occurrence with all concrete and concrete products. Efflorescence does not affect the quality of the product and will fade over time or can be removed with cleaning products.