

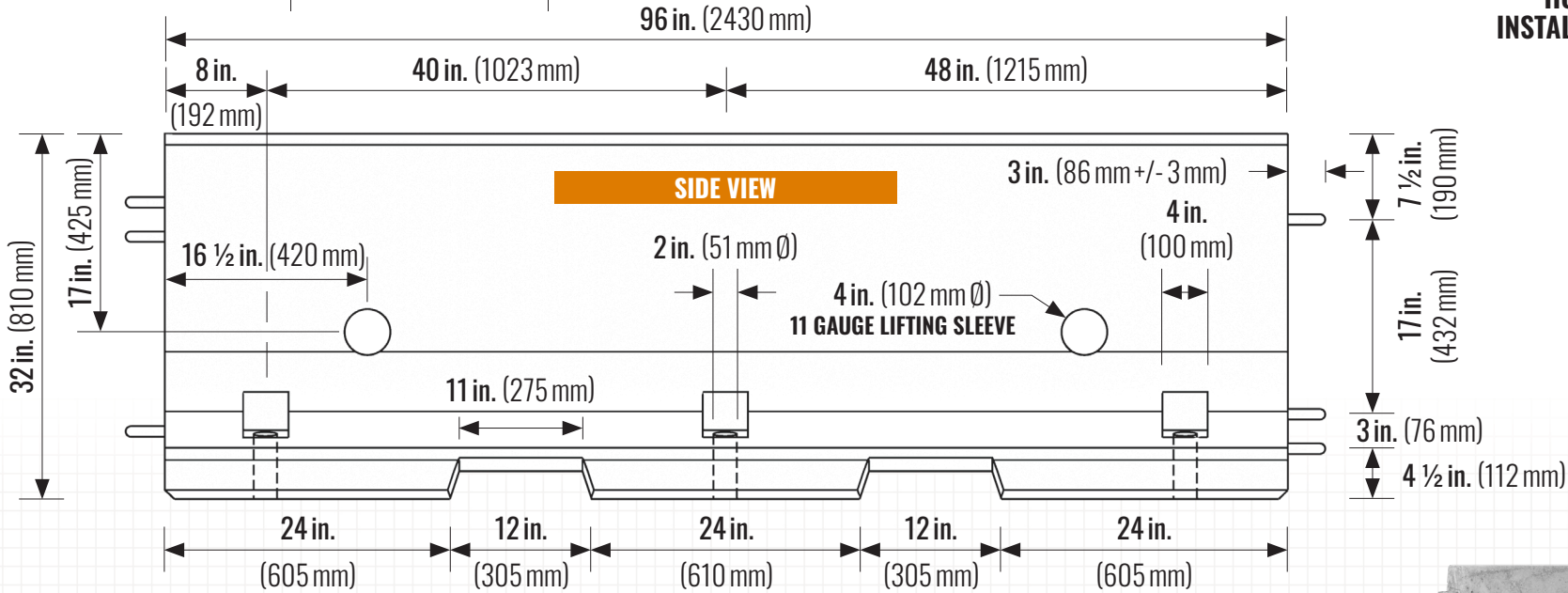

PERSPECTIVE VIEW

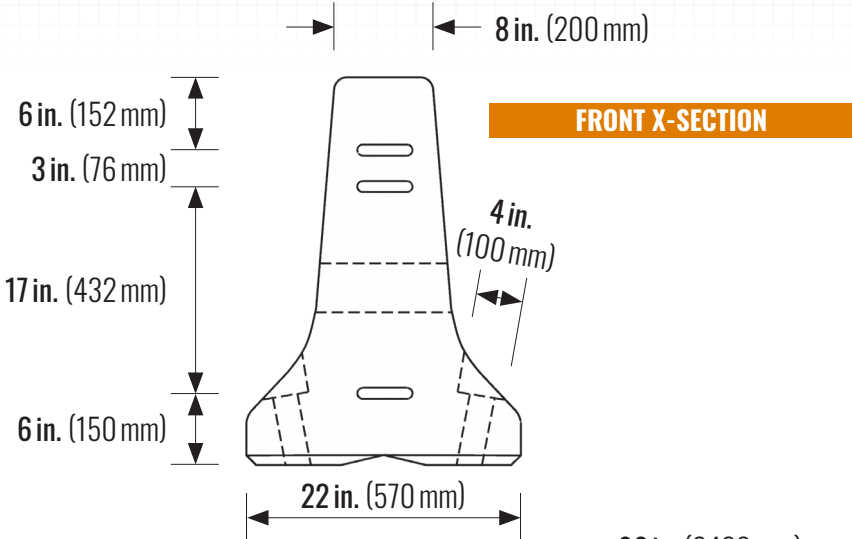
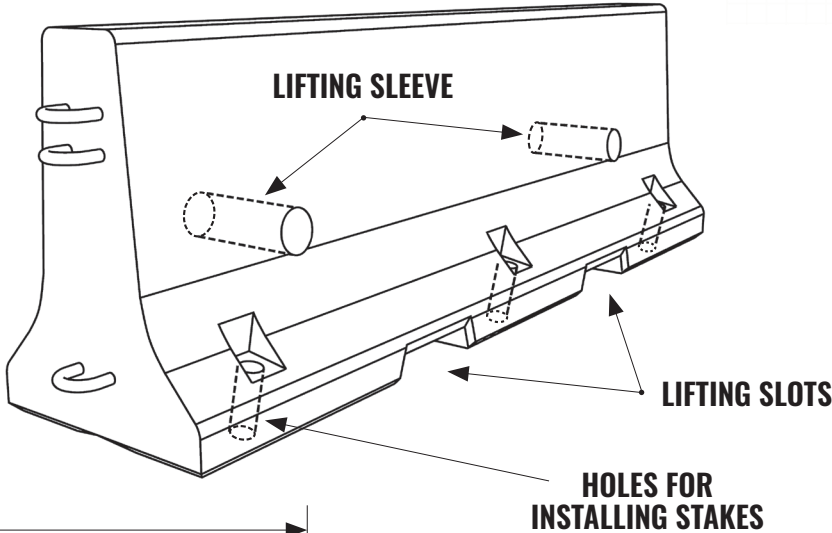

DETAILS:

2500 mm (8 ft.) = 1510 kg (3330 lbs)

DETAILS:

F-shape D.O.T. compliant traffic barrier - NCHRP 350 test level 3 Interconnecting barriers with hot-dipped galvanized hooks & pins

PHYSICAL PROPERTIES:

Meets the requirements of CSA A23.1 and A23.4
Compressive Strength: Min. 35 MPa @ 28 Days
Concrete Contains: 5.0-8.0% Entrained Air

