

PERSPECTIVE VIEW

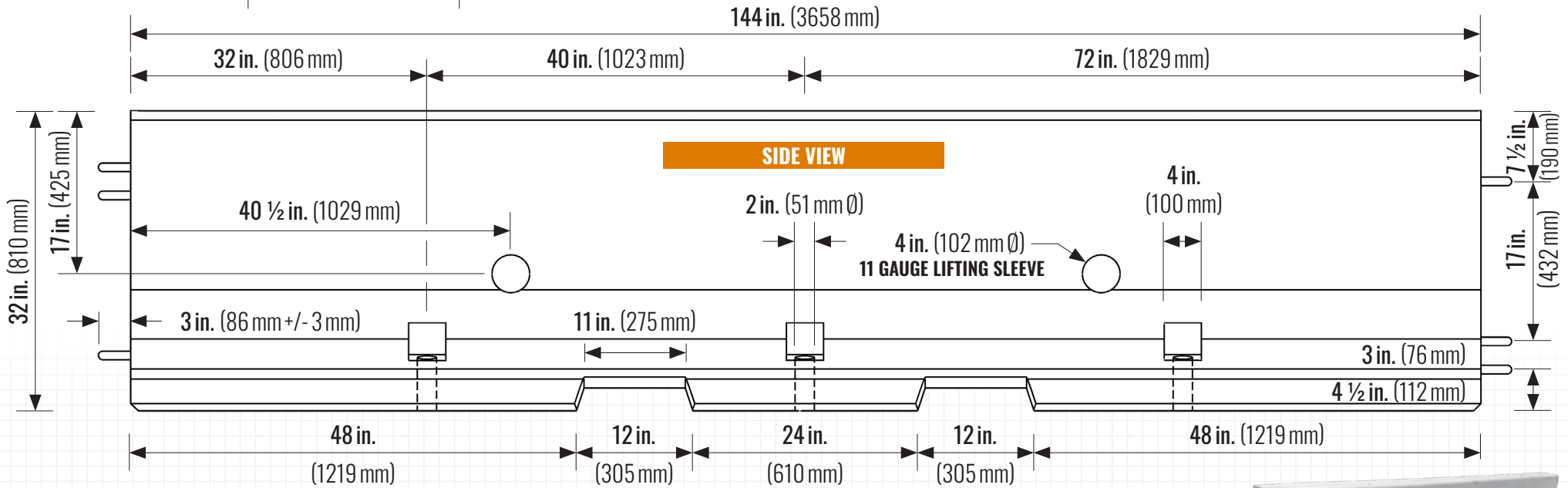
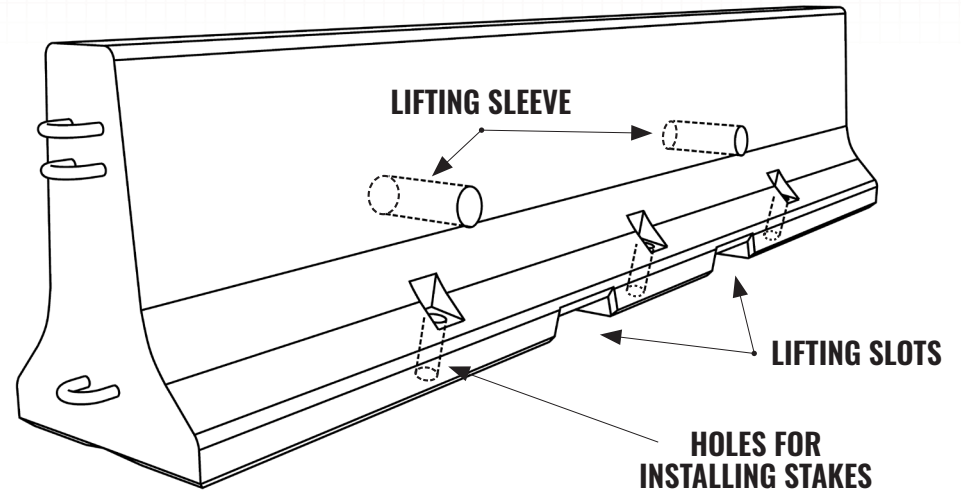

DETAILS:

3658 mm (12 ft.) = 2236 kg (4930 lbs)

DETAILS:

F-shape D.O.T. compliant traffic barrier - NCHRP 350 test level 3
Interconnecting barriers with hot-dipped galvanized hooks & pins

PHYSICAL PROPERTIES:

Meets the requirements of CSA A23.1 and A23.4
Compressive Strength: Min. 35 MPa @ 28 Days
Concrete Contains: 5.0-8.0% Entrained Air

