

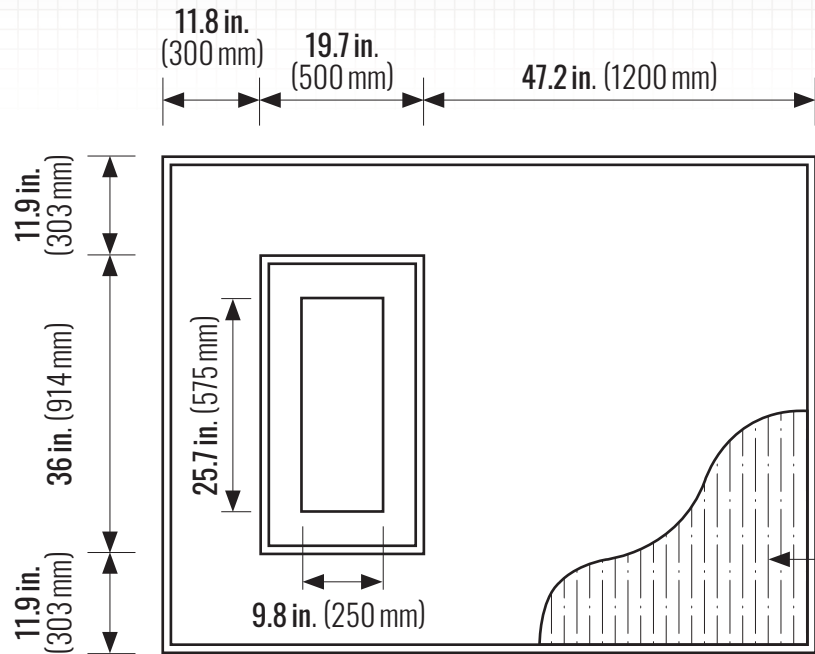

caseyconcrete.ca

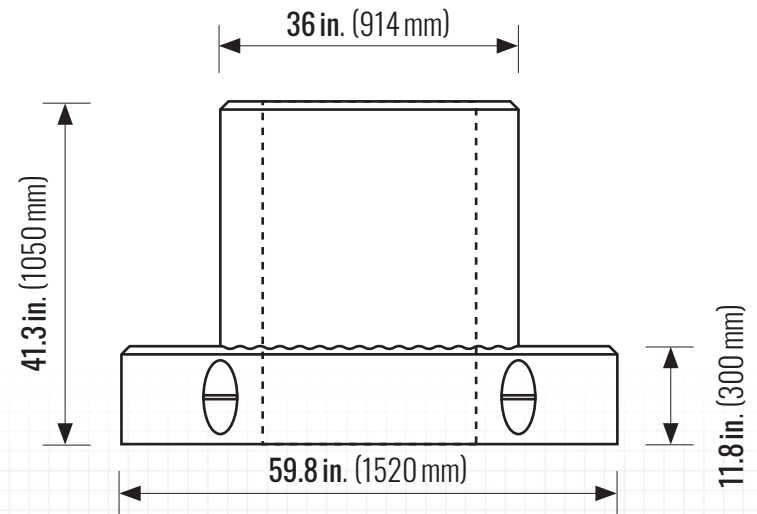

TOP VIEW

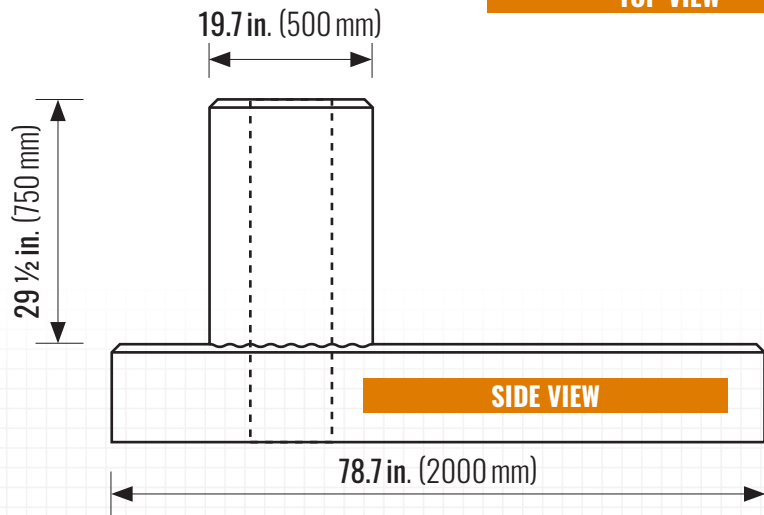
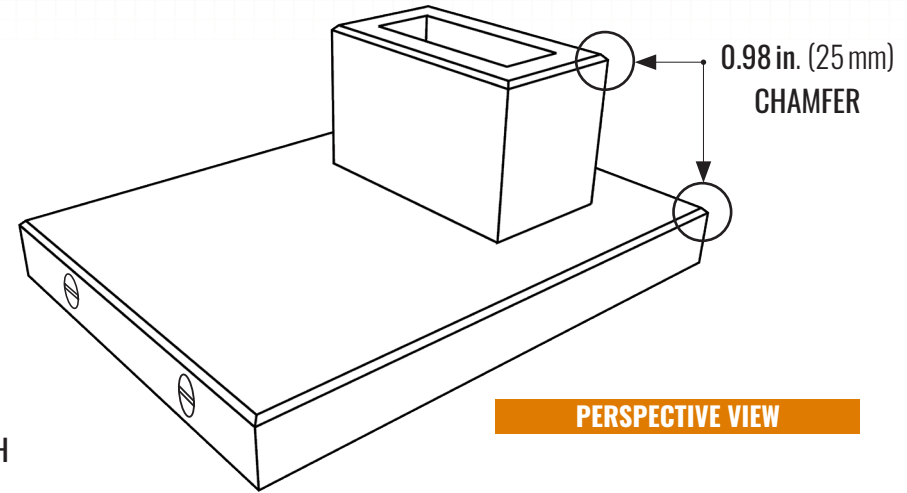

PACKAGING:

Weight: 2325 kg (5125 lbs)
Volume: 0.98 m³

PHYSICAL PROPERTIES:

Meets the requirements of CSA A23.1 and A23.4
Compressive Strength: Min. 35 MPa @ 28 Days
Concrete Contains: 5.0–8.0% Entrained Air