

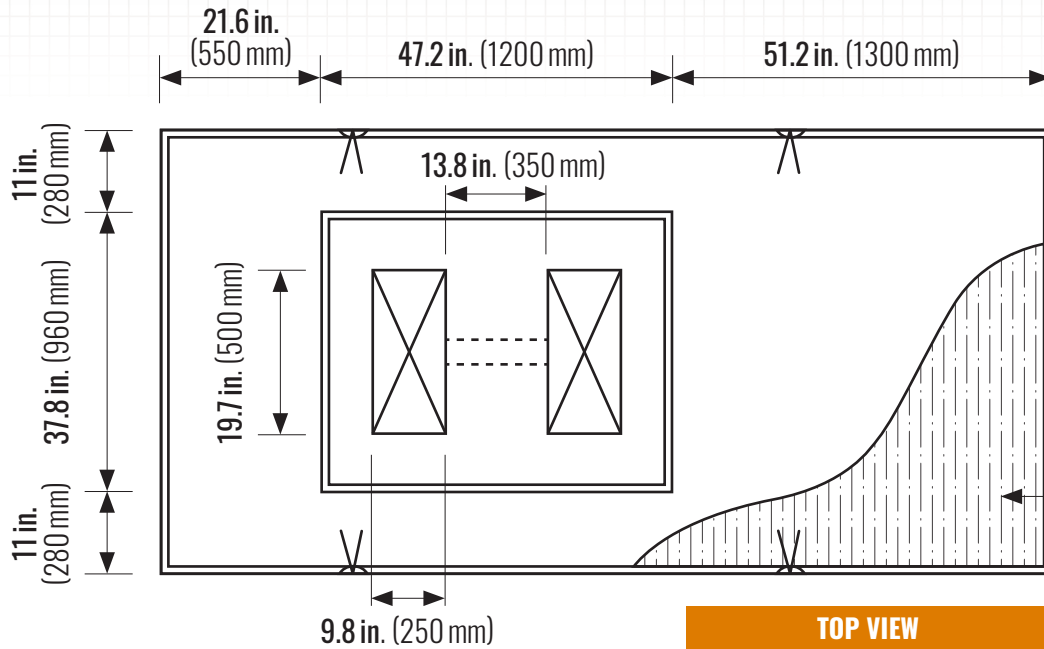

DOUBLE TRAFFIC CONTROL UNIT

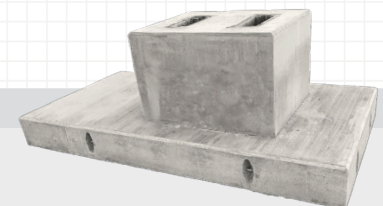

BROOM FINISH
TO ALL TOP
PAD SURFACE

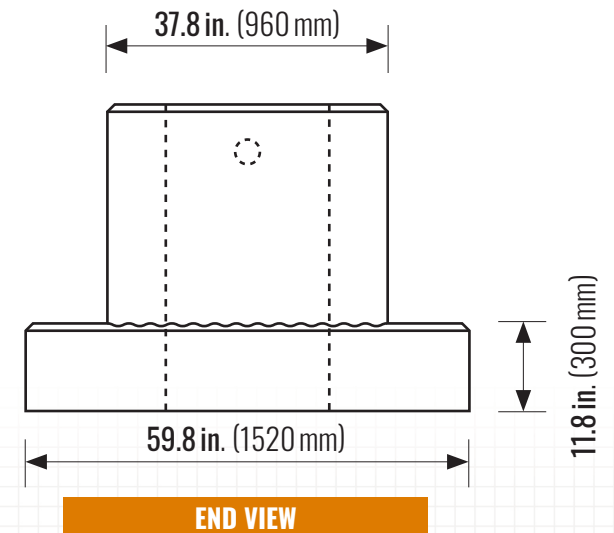
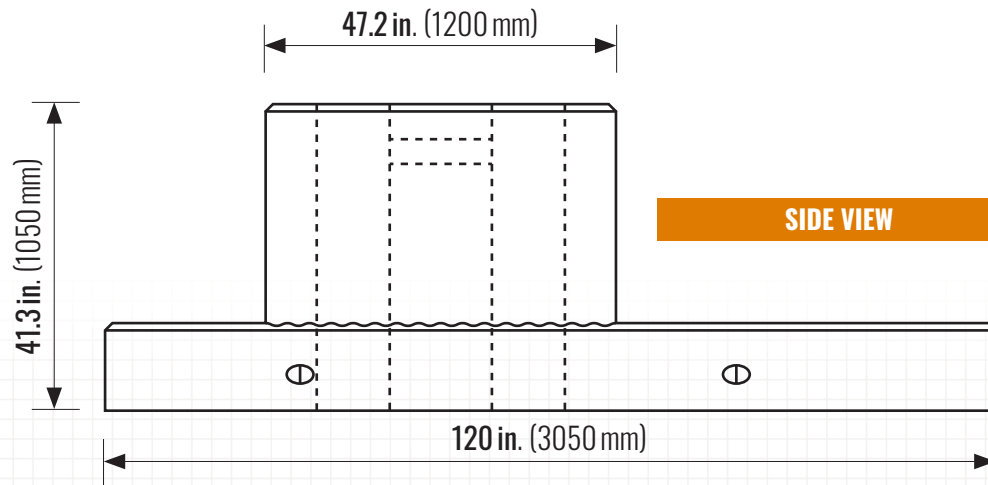
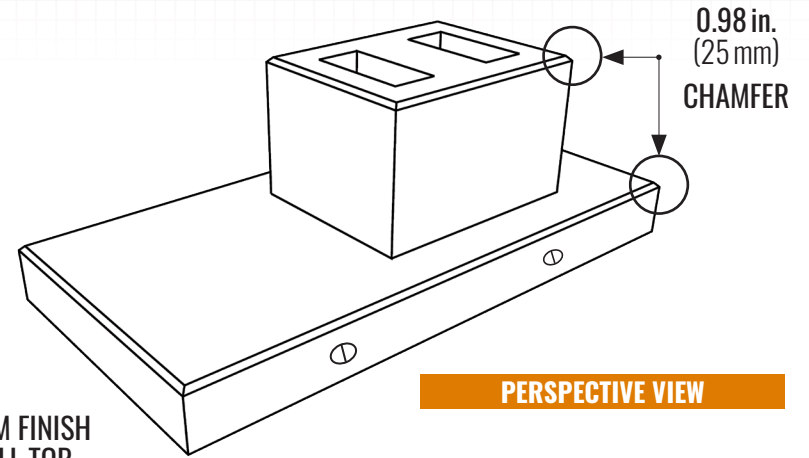

PACKAGING:

Weight: 4870 kg (10736 lbs)
Volume: 2.10 m³

PHYSICAL PROPERTIES:

Meets the requirements of CSA A23.1 and A23.4
Compressive Strength: Min. 35 MPa @ 28 Days
Concrete Contains: 5.0-8.0% Entrained Air